



CONTRA COSTA
ENVIRONMENTAL HEALTH DIVISION
2120 DIAMOND BOULEVARD, SUITE 100
CONCORD, CA 94520
(925) 608-5500 (925) 608-5502 FAX
www.cchealth.org/eh/



DIRECTIONS AND REQUIREMENTS FOR TEMPORARY FOOD FACILITIES AT FARMERS MARKETS

APPLICATION FEE IS NON-REFUNDABLE (*SERVICE FEES ARE ADDITIONAL. REFER TO FEE SCHEDULE*)

GENERAL INFORMATION

This handout describes permit requirements, California Retail Food Code (Cal Code) requirements and event coordinator responsibilities. This handout is not a substitute for Cal Code, where discrepancies in the verbiage between this handout and Cal Code arise. The person in charge of organizing the community event is referred to as the Market Manager/Coordinator.

A Temporary Food Facility is a food facility that operates at a fixed location for the duration of an approved community event. A community event is an event that is civic, political, public or educational in nature, including public gathering events.

Non-profit Charitable Temporary Food Facilities may operate up to four times annually. These four time periods shall not exceed 72 hours each.

MARKET MANAGER/COORDINATOR RESPONSIBILITIES

The Market Manager/Coordinator is responsible for submitting the following at least 2 weeks prior to market quarter start: **(1)** completing the Certified Farmers Market Permit TFF Application (page 1); **(2)** creating List of ALL participating Temporary Food Facility Operators; **(3)** Compiling and signing Temporary Food Facility Operator Information for Farmers Market forms (page 2) for each food booth/truck operator; **(4)** submitting all fees; and **(5)** ensuring copies of the requirements for *Temporary Food Facilities at Farmers Markets* [page 3-7] is given to each booth operator (including non-profits). Market Manager/Coordinator is to ensure that food booth operators attach Veteran DD214, 501 (c) 3 IRS non-profit status letters, Cottage Food Operation (CFO) registration/permit, Mobile Food Facilities current health permit and current health permits for commissaries/vendors located outside of Contra Costa County as needed. **(6)** The site map must list all food/beverage vendors and indicate the locations of each booth.

PERMIT REQUIRED

A permit to operate a temporary food facility is required before the event may open for business. It is the Market Manager/Coordinator's responsibility to also contact any other agencies, such as State Alcohol Beverage Control Board, Fire Department, City or County Planning Department, or Building Department to obtain permits and approval.

APPLICATION PROCESS

Complete Certified Farmers Market Temporary Food Facility Permit Application.

List of all participating Temporary Food Facility Operators.

Temporary Food Facility Operator Information form (page 2) for **each** proposed booth/table/MFF vehicle.

Proof of non-profit (501 (c) 3 IRS status letter) or Veteran status (DD214 status letter), Copy of Mobile Food Vendor current health permit.

Site map showing location of booths, restrooms, and garbage and list of all food/beverage vendors.

One payment of all fees - Quarterly Permit Dates: Dec 1 - Feb 28 March 1 - May 31 June 1 - Aug 31 Sept 1 - Nov 30

Failure to submit the application at least (2) weeks before Market quarter start will result in a \$150.00 late fee.

FEES

Fees are subject to change. Please refer to the most current fee schedule: www.cchealth.org/eh/

The Market Manager/Coordinator/Permit Holder of the event is responsible for all violations and/or penalty fees.

- \$45.00 non-refundable application fee for each quarterly market event including for-profit, non-profit and Vet exempt events.
- \$196.00 1-2 **for-profit** booths/tables & out of county food trucks, \$142.00 3-7 for-profit booths/tables, \$126.00 8 + for profit booths/tables,
- **Non-profits** do not pay booth fee but must provide proof of their non-profit 501 (c)3 status, such as a copy of the official IRS confirmation or confirmation pending letter.
- **Veterans** do not pay booth fee but must provide a copy of their DD214.
- **CC County licensed Mobile Food Vehicles** do not pay booth/table fee, but must provide a copy of a valid permit to Market Manager/Coordinator.
- **Reinspection fees**
\$199.00 per hour - normal business hours
\$266.00 per hour - non-business hours, including weekends

TRAINING AND PRE-MEETING AVAILABLE

Environmental Health Specialists (EHS) are available for training and pre-meetings with booth operators and Market Manager/coordinators for \$199.00 per hour or \$266.00 after normal work hours. For information on scheduling a training session or pre-meeting, please contact Contra Costa Environmental Health at (925) 608-5500 and ask for the Temporary Event Coordinator for questions specific to community events, OR Certified Farmer's Market Coordinator for questions specific to Certified Farmer's Market.



CONTRA COSTA
ENVIRONMENTAL HEALTH DIVISION
 2120 DIAMOND BOULEVARD, SUITE 100
 CONCORD, CA 94520
 (925) 608-5500 (925) 608-5502 FAX
 www.cchealth.org/eh/



CERTIFIED FARMERS MARKET TEMPORARY FOOD FACILITY PERMIT APPLICATION

Failure to submit the application at least (2) weeks before the event will result in additional fees.

Please see the current fee schedule. Payment to be received in one check/credit card form with completed application packet.

Attach the following forms for EACH food booth and indicate locations of each booth on a site map (copy of Checklist must be posted in each Food Booth): Temporary Food Facility Operation Information for Farmers Market Checklist Form (Pg 2) signed and dated by the Booth Operator and Market Manager/Coordinator, Commercial Facility Agreement (if applicable), current copy of CFO Class A Registration/Class B Permit, current copy of current health permit for Mobile Food Facilities and current out of county Commissary/Facility Permits (if applicable).

I. MARKET INFORMATION:

CERTIFIED FARMERS MARKET NAME:		INDICATE QUARTER: 1st, 2nd, 3rd, 4th	EVENT DATES/DAY OF WEEK:	EVENT TIMES:
SITE ADDRESS:			CITY/STATE/ZIP CODE:	
FEDERAL TAX ID #:	NON-PROFIT TAX ID#	# OF VETERAN'S EXEMPT (WITH DD-214): _____		
# OF FOR-PROFIT BOOTHS: _____	# OF NON-PROFIT BOOTHS (WITH IRS PROOF): _____	TOTAL # OF BOOTHS/TABLES _____		
# OF MOBILE FOOD TRUCKS: _____				
MARKET MANAGER/COORDINATOR:	DAYTIME PHONE: _____	EMERGENCY PHONE: _____		
	FAX: _____			
ADDRESS:	CITY, ZIP	EMAIL:		

II. Attach a sketch or site map of event layout and location of restrooms and garbage.

MARKET LOCATION DETAILS:

Is water supplied and available for each food booth?

Indoors Outdoors

Yes No

Is electricity supplied and available for each food booth?

Yes No

Are approved handwashing stations available at each booth?

Yes No

Method of liquid waste disposal for food booths: _____

Number of chemical toilets provided: _____

Sanitary garbage disposal company and number of dumpsters: _____

I understand that improperly handled food served to the public can cause illness. I further understand that to prevent foodborne illness, and to encourage the sanitary handling of food, temporary food facilities should be operated and equipped to comply with applicable requirements of the **California Health & Safety Code, Division 104, Part 7, California Retail Food Code**. I have been given a copy of the handout **Requirements for Temporary Food Facilities**.

Signature(s) of Market Manager/Coordinator(s): _____ **Date:** _____

FOR OFFICE USE ONLY					
FA #:	AR#:	PR #:	PE #:		REHS:
AMOUNT DUE:	AMOUNT PAID:		RECEIPT #:	RECEIVED BY:	
\$	\$				
CHECK #:	<input type="checkbox"/> CASH <input type="checkbox"/> CREDIT CARD <input type="checkbox"/> MC <input type="checkbox"/> VISA		DATE RECEIVED:	SUPERVISOR:	

To be Completed by each Food Booth/Mobile Food Facility Operator and submitted to Market Manager/Coordinator

TEMPORARY FOOD FACILITY OPERATOR INFORMATION FOR FARMERS MARKET		
NAME OF CERTIFIED FARMERS MARKET:	DATE(S):and days of week:	TIME(S):
LOCATION:	ONSITE CONTACT PERSON:	
NAME OF BOOTH, ORGANIZATION OR COMPANY:	PHONE #:	
MAILING ADDRESS , CITY & ZIP OF BOOTH OPERATOR:	EMAIL ADDRESS OF BOOTH OPERATOR:	
TYPE: For profit Non-profit-501c3 Veteran Exempt -DD214 CC MFF - copy Permit Out of County Food Truck - copy county health permit CFO-Copy Regist/Permit		

Food to be sold or given away: <i>(including beverages, condiments & ice)</i>	Source(s) of all food purchased/ prepared: <i>e.g. Restaurant/Caterer, Cottage Food Operation, Costco, Winco, Market, etc</i>	Type of cooking equipment to be used: <i>(e.g. barbeques, fryers, griddles, etc.)</i>

Food Booth Operator Checklist (complete each item)

All food must be from an approved source or facility.

- | | | |
|--|-----|----|
| 1. I understand I cannot prepare foods and beverages at home. | Yes | No |
| 2. I am preparing all foods on-site. | Yes | No |
| 3. I am preparing approved foods in my CC County registered/permited Cottage Food Operation (CFO). | Yes | No |
| 4. I am preparing all foods in an approved Commercial Facility. | Yes | No |

Address of Commercial Facility w/ commercial facility agreement attached: _____

- | | | |
|---|-----|----|
| 5. All food/beverages will be prepackaged and no food preparation will be conducted in the booth | Yes | No |
| 6. I will provide an accurate probe thermometer to measure the hot and cold holding of potentially hazardous foods during all times of booth operation. | Yes | No |

I am providing the following minimum handwashing facilities:

- | | | |
|---|-----|----|
| 7. Water supply dispenser (5-10 gallons) with hands free spigot.
<i>(Any booth with open food or food preparation will be required to have water temperature of 100°F for handwashing. Prepackaged food/beverage booths do not need 100°F water for handwashing)</i> | Yes | No |
| 8. One separate tub (bucket or basin) for the collection of rinse/waste water. | Yes | No |
| 9. Pump-style soap container (or squeeze type). | Yes | No |
| 10. Paper towels and trash receptacle. | Yes | No |

I am providing the following items within my booth for the sanitary cleaning of food preparation utensils:

- | | | |
|---|-----|----|
| 11. Three (3) deep tubs (basin 6 – 8 inches minimum); one with detergent & water, the second with clean rinse water and the third with sanitizing solution. | Yes | No |
|---|-----|----|

I am protecting the unpackaged food and food preparation areas from insects, dust, and the public by the following method:

- | | | |
|---|-----|----|
| 12. A booth with walls and ceiling constructed either of wood, canvas, plastic, or similar material with fine mesh fly screening, completely enclosing open food areas. | Yes | No |
| 13. A booth with cleanable flooring (concrete, asphalt, clean tarps and smooth wood are acceptable). | Yes | No |
| 14. Overhead protection and approved floor cover because I am selling prepackaged food/ beverages only. | Yes | No |

I have read the handout on Requirements for Temporary Food Facilities and will follow the guidelines provided in this handout.

Completed by (signature): _____ **Date:** _____

Please print name: _____

Market Manager/Coordinator: _____ **Date:** _____



**CONTRA COSTA
ENVIRONMENTAL HEALTH DIVISION**
2120 DIAMOND BOULEVARD, SUITE 100
CONCORD, CA 94520
(925) 608-5500 (925) 608-5502 FAX
EMAIL: cocoeh@cchealth.org
WEBSITE: <http://cchealth.org/eh>



COMMERCIAL/PRODUCTION KITCHEN AGREEMENT
FOR TEMPORARY FOOD EVENT VENDORS

1. TO BE COMPLETED BY FOOD BOOTH OPERATOR

Owner Name:	Food Booth Name:
Mailing Address (City, State, Zip):	
Telephone:	Email:

I hereby declare that the above information is current, true and correct to the best of my knowledge and agree to use the Commercial/Production Kitchen in accordance with the California Health and Safety Code.
Signature: _____ **Print Name:** _____ **Date:** _____

2. TO BE COMPLETED BY COMMERCIAL/PRODUCTION KITCHEN OWNER OR OPERATOR

FACILITY CURRENTLY PERMITTED BY HEALTH DEPARTMENT:	<input type="checkbox"/> YES	<input type="checkbox"/> NO
Commercial/Production Kitchen Name:		
Facility Address (City, State, Zip):		
Owner Name:	Phone:	Email:

I will provide the above-named food booth operator access to the following (if available):

<input type="checkbox"/> Hand washing facilities	<input type="checkbox"/> Ice machine or cooling equipment
<input type="checkbox"/> Food preparation area	<input type="checkbox"/> Potable water
<input type="checkbox"/> Food preparation sink	<input type="checkbox"/> Garbage and refuse disposal
<input type="checkbox"/> 3-Compartment warewash sink	<input type="checkbox"/> Dry food/equipment storage
<input type="checkbox"/> Refrigeration/Freezer storage	<input type="checkbox"/> Chemical storage
<input type="checkbox"/> Cooking equipment and ventilation hood	<input type="checkbox"/> Restroom with hand washing facilities

If Commercial/Production Kitchen holds a valid Environmental Health Permit to operate, include a copy of a valid health permit. I certify that the business named in Section 1 is operating out of the above Commercial/Production Kitchen.
Owner/Manager Signature: _____ **Print Name:** _____ **Date:** _____

3. OUT OF COUNTY PRODUCTION KITCHEN (SIGNED BY AGENCY WITH JURISDICTION)

The above listed Commercial/Production Kitchen is permitted in _____ County. The above checked (see section 2) requirements are available at the proposed Production Kitchen/approved facility.
Include a copy of valid Environmental Health (EH) Permit and obtain a signature from an authorized EH inspector from that County.
REHS Signature: _____ **Print Name:** _____ **Date:** _____
Telephone: _____ **Email:** _____

FOR OFFICE USE ONLY

FA#:	PR#:	PE:	Received By:	Date Received:
REHS:			Date:	

**REQUIREMENTS FOR
TEMPORARY FOOD FACILITIES AT FARMERS MARKETS**
(Pages 3 – 7 to be retained by each vendor/booth operator)

SANITATION REQUIREMENTS: Temporary food facilities must comply with the following standards

Food Sources (Section 114339)

- All food must be from approved commercial sources.
- **No home-prepared foods or foods from unlicensed food facilities are allowed.**
- Shipping tags must be kept on-site for all shellfish (i.e., oysters, clams, mussels, scallops).
- Provide approved labels for all prepackaged food items.

Food Preparation (Section 114341)

- Food must be prepared inside an approved food booth or inside a permitted commercial food facility. If the food is prepared off site, provide a copy of the facility's health permit.
- The only cooking allowed outside the booth is an open flame BBQ or grill or other propane fueled cooking equipment that the fire department does not allow inside of the booth.
- Once the food items are cooked, they must be brought into a fully enclosed booth for preparation.
- Food must be protected at all times, and in cases where potential contamination may occur such as rain, wind, or overhead contaminants, other methods of food protection must be provided.
- Contact the local fire department for additional requirements or permits regarding cooking equipment at a Temporary Food Event.

Temperature Control of Potentially Hazardous Foods (PHF) (Section 114343)

- PHF's include meats, seafood, poultry, cooked rice, cooked beans, cooked vegetables, many cheeses, cut melons, tofu, eggs, and sprouts. At the end of the day, hot and cold potentially hazardous foods must be discarded.
- During operating hours, PHF must be kept at/or below 45° F for up to 12 hours in any 24-hour period.
- At the end of the operating day, any PHF that is held at 45° F shall be destroyed in an approved manner.
- At the end of the operating day, PHF that is held at/or above 135°F shall be destroyed in an approved manner.
- Hot foods must be held in approved hot-holding units (e.g., steam table, hot plate, etc.).
- Potentially hazardous foods must be transported at/or below 45° F or at/or above 135° F in an approved container capable of maintaining these temperatures. Frozen food must be transported frozen with no signs of thawing.
- Before placing hot foods in a steam table or other type of holding unit, they must be first heated to at least 165° F.
- An accurate food service thermometer must be provided if the booth is handling potentially hazardous foods. The device must be accurate to ± 2° F and sanitized prior to use.

Cooking Temperatures (Section 114004)

- Minimum internal cooking temperatures are as follows:
 - Poultry, stuffed foods, reheated foods 165° F (for at least 15 seconds)
 - Ground beef or pork, (comminuted meat) 155° F (for at least 15 seconds)
 - Eggs, fish and single pieces of beef or pork 145° F (for at least 15 seconds)
 - Vegetables for hot holding 135°F

Food Preparation Handwashing Station (Section 114358)

The handwash station must be operational prior to beginning food handling operations. Container must be capable of providing a continuous stream of water that leaves both hands free to allow vigorous rubbing with soap and warm water for 10 to 15 seconds.

- Provide a 5-gallon warm water (from an approved source) reservoir with a hands-free spigot that drains into a 5-gallon waste bucket. Temperature of the water must be at least 100°F.
- For some operations or events, a more substantial handwashing station may be required, including a sink supplied with hot water.
Event coordinators shall consider these sinks for larger high-risk operations.
- Provide single service soap (e.g., pump style dispenser) and paper towels.
- A handwashing station is not required for facilities that handle only prepackaged food.

Warewashing Facilities (Section 114351)

- Provide three 5-gallon buckets (or equivalent): **First bucket:** clean water and detergent. **Second bucket:** clean rinse water. **Third bucket:** bleach and clean water (1 tablespoon bleach per 1 gallon water). For some operations or events a more substantial utensil washing station will be required.
- Provide sanitizer test strips for the sanitizer used (e.g., chlorine, quaternary ammonia).
- Utensils include knives, tongs, scoops, forks, pots, cutting boards, probe thermometers, etc.
- Utensils must be cleaned and sanitized throughout the day
- Utensils handling potentially hazardous foods must be cleaned and sanitized at least once every 4 hours.
- Warewashing sink may be shared by no more than four facilities that handle non-prepackaged food if the sink is centrally located and is adjacent to the sharing facilities.

Wastewater Disposal

- Water and liquid wastes (including waste from ice bins and beverage units) must drain into a leak-proof container.
- Wastes must be disposed of into an approved sewer system or holding tank.
- Wastes must not be drained to the ground surface or into a storm sewer.

Food Handlers

- Food handlers must be in good health and wear hair restraints.
- Food handlers must wash their hands prior to the start of food preparation, after smoking, when switching from one food type to another, before putting on gloves, after using the restroom, and whenever hands may have become contaminated.
- Clean garments must be worn.
- Whenever practical, food handlers must use tongs, gloves, or single-service wax paper for serving ready-to-eat foods.
- Smoking is prohibited inside or around the booths.

Condiments and Customer Utensils

- Condiments and customer utensils must be protected from contamination
- Condiments and customer utensils must be in individual packages, served from inside the booth, or provided from approved dispensers.
- Facility shall provide single use articles for use by the consumer.

Toilet Facilities

- Approved toilet facilities must be located within 200 feet of each booth.
- There must be at least one toilet facility for each 15 employees.
- Handwashing facilities equipped with soap and paper towels must be located within or immediately adjacent to toilets. Handwashing in permanent facilities must be supplied with hot and cold running water. **Handwashing for toilets is required in addition to the handwashing station required in the booths.**

Equipment

- All equipment must be easy to clean and in good repair. Food-contact surfaces must be commercial-grade, made of non-toxic components, and comply with applicable NSF standards.
- Hot and Cold holding equipment shall be provided to ensure proper temperature control during transportation, storage and operation of the TFF.
- Equipment shall be located and installed to prevent food contamination.
- The Fire Department may have additional requirements such as the following:
 - Cooking equipment must also be approved for use by the local fire department.
 - Only approved fuels are to be used. The use of kerosene or gasoline is prohibited.
 - All fueling or refueling must be done outside of the booths and only when the appliance is shut off and cooled down.
 - When sterno is used, a metal or non-combustible barrier must be provided to protect the table-top or surface from flame impingement.
 - Open-flame devices may require a special permit.
 - Propane cylinders are prohibited inside the booth. Cylinders must be kept upright, be of approved size, and provided with approved hoses and fittings. Shut-off valves must always be accessible.
 - Electrical appliances, cords, and accessories must be in good repair and UL listed. Household type extension cords are prohibited. All extension cords must be rated for the intended use. Camp stoves are prohibited.

Storage

- Food and utensils must be stored inside the booth at least 6" above the ground.
- Food and utensils must be stored inside the booth.

Garbage

- Garbage must be stored in leak-proof and fly-proof containers, and serviced as needed.

Animals

- Live animals are prohibited inside the booth.
- Live animals must be at a minimum of 20 feet away from food/beverage booths at all times.

Booths (for operators handling unpackaged foods, including ice)

- A fully enclosed (with 16 mesh per square inch screens), fly-proof booth must be provided unless the booth is selling/handling only individually prepackaged foods that have been packaged in an approved, fully enclosed commercial facility. **Food compartments are not a substitute for an enclosed booth.**
- The booth must be large enough to accommodate all operations including storage, food preparation, handwashing, cooking, and utensil washing. Many vendors will require a double booth (or larger). Supplies and non-PHF food in factory sealed containers may be stored adjacent to the booth (provide overhead protection) or in nearby storage units.
- Pass-thru windows must be provided. The maximum size of a pass-through window is not to exceed 216 square inches.
- Pass-through windows and doors must be equipped with tight-fitting flaps or doors.
- Booths using adjoining barbeque facilities must be equipped with a pass-thru window between the barbecue and the booth.
- Booths operating on grass or dirt must use plywood or other approved material (e.g. concrete, asphalt, tight wood or other similar cleanable material) for floor surfaces and kept in good repair.
- The name of the facility, city, state, zip code and name of the operator must be legible and clearly visible to patrons. Facility name shall be a minimum of 3 inches high and be of a color contrasting with the surface on which it is posted. Letters and Numbers for the City, State and Zip Code shall be a minimum of one inch high.

The Fire Department may have additional requirements such as the following:

- An exit door (not a flap) must be provided at least 24" wide. Exits must be kept clear and unobstructed.
- Outdoor cooking equipment must be kept at least 5 feet from the booth or other combustibles.
- Generators are not to be refueled while running. Refueling is to be done only when the unit has cooled down.
- Cooking areas are to be protected and secure from public access.
- Even if you are not cooking in your booth, proximity to other booths may require that your booth meets these requirements.
- Contact the local fire department for any further requirements or clarification regarding fire department regulations at Temporary Food Events.

HANDWASH AND UTENSIL WASH SETUP

Utensil wash station setup for the sanitary cleaning of cutting boards and utensils. Utensils include knives, tongs, scoops, forks, pots, and cutting boards, probe thermometers, etc.

1. Provide **three** 5-gallon buckets (or equivalent) for utensil washing:
 - a. First bucket: clean water and detergent.
 - b. Second bucket: clean rinse water.
 - c. Third bucket: sanitizing solution and clean water (1 tablespoon bleach per 1 gallon water).
2. Provide sanitizer test strips for the sanitizer used (e.g., chlorine, quaternary ammonia).
3. Utensils handling potentially hazardous foods must be cleaned and sanitized at least once every four hours.

UTENSIL WASH SETUP

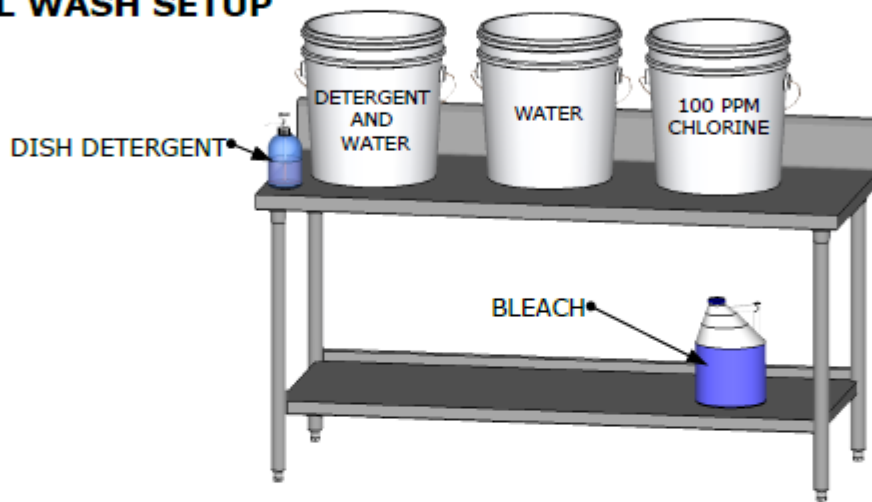

Handwashing facilities

1. Provide a 5-gallon water reservoir with a hands-free spigot that drains into a 5-gallon waste bucket or basin.
2. Provide single service soap (e.g., pump style dispenser or squeeze type)
3. Paper towels and trash receptacle.

HANDWASH SETUP

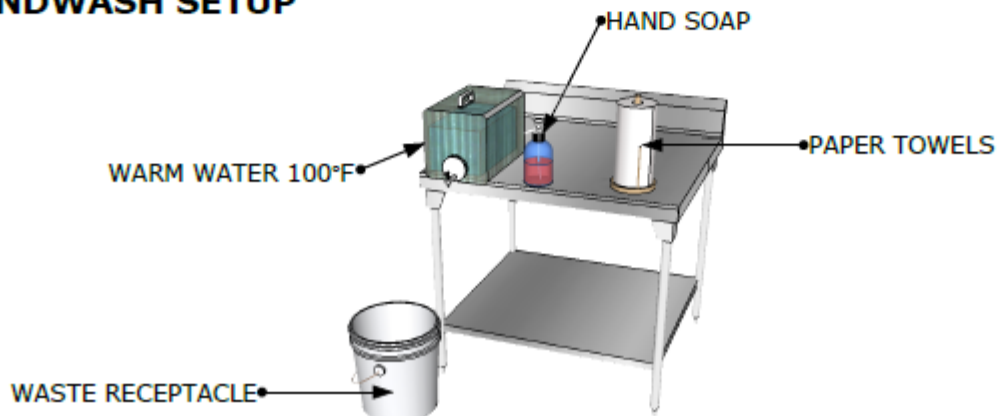

Fully enclosed booth with pass-through windows

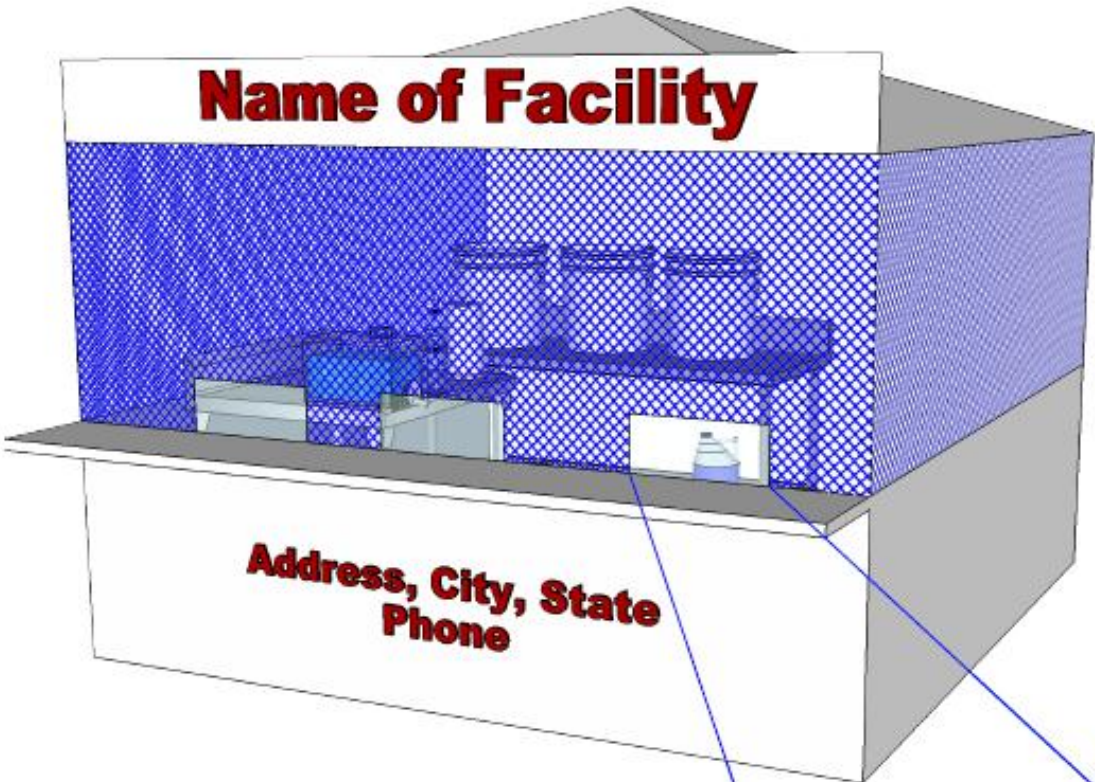

Detail of pass-through window requirement (216 square inches maximum)

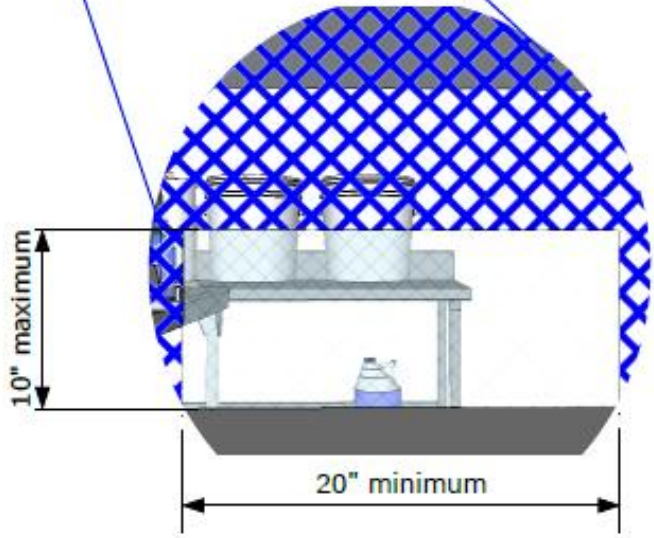



Contra Costa Environmental Health
 2120 Diamond Blvd., Suite 100
 Concord, CA 94520
 Phone: (925) 608-5500
 Fax: (925) 608-5502
www.cchealth.org/eh/

CREDIT CARD PAYMENTS

Payments can be made using Visa, Mastercard, and Discover

CHECK ONE: **BUSINESS CARD** **PERSONAL CARD**

If you checked BUSINESS CARD above, please include the NAME OF BUSINESS ON CARD:

NAME OF BUSINESS ON CARD:		
NAME ON CARD:		
PAYOR ADDRESS (if different from business address)		
CARD NUMBER	EXPIRATION DATE Month Year	
SECURITY CODE (CVV):	PHONE NUMBER: ()	AMOUNT PAID:
EMAIL ADDRESS:		
ACCOUNT RECEIVABLE# (AR #):	FACILITY NAME:	PROCESSED BY:

PAYMENT INFO RECEIVED:

- PHONE
- FAX
- E-MAIL
- WALK-IN
- MAILED IN

SIGNATURE OF CARDHOLDER:	DATE:
--------------------------	-------